

YOKOTA

SHUT - OFF 2 BLADE • IMPULSE WRENCHES

MODEL (YES. NO.)	TOOL NO.
YXS-900 (00)	0243 0000 00 00

■ EXPLODED VIEW

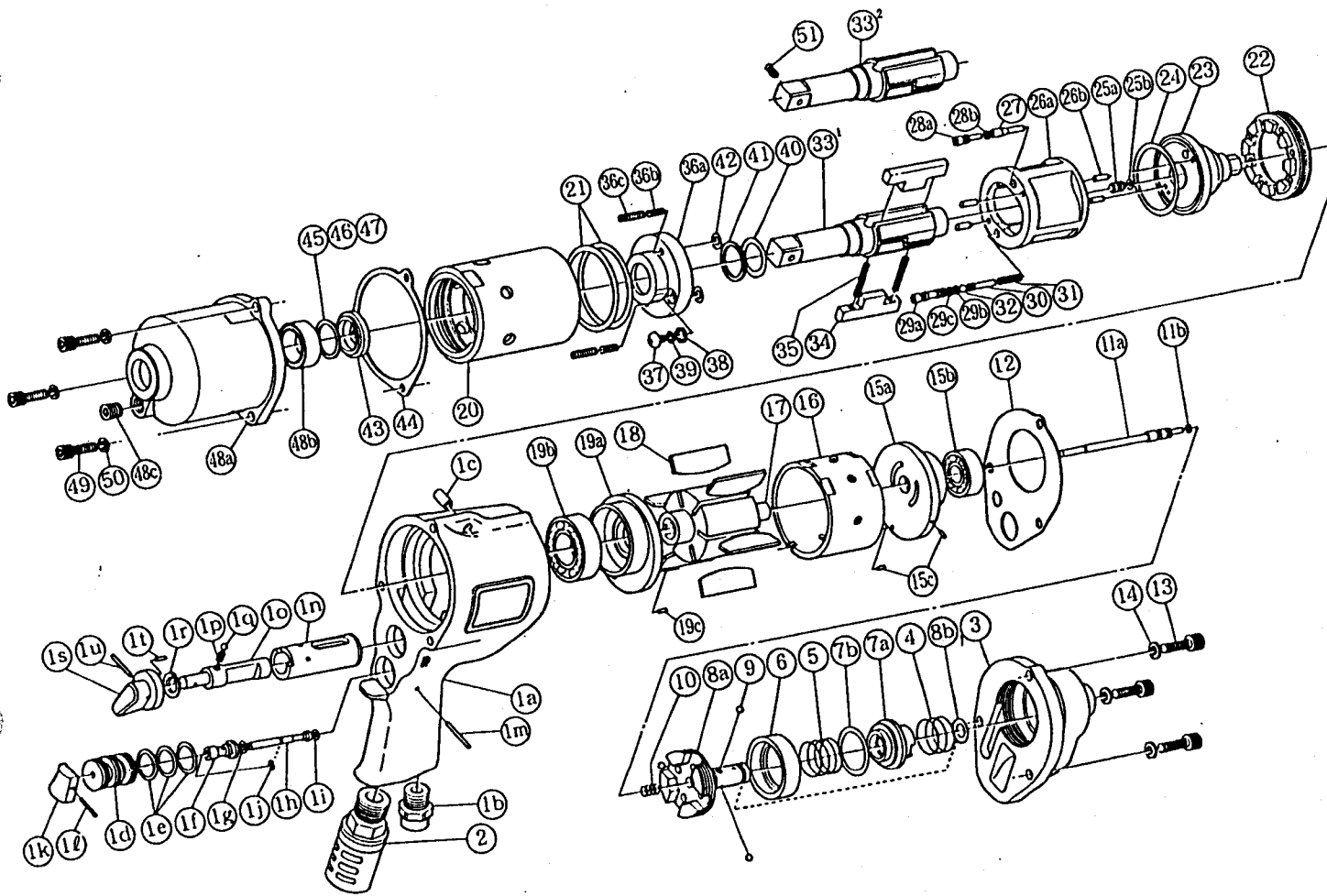

YOKOTA EUROPA BV

DE RUYTERKADE 142, AMSTERDAM PHONE (020) 25 29 53 TELEXNR ; 14022

PARTS LIST

No.	Name of Parts	Per Set	Parts No.
1	Motor Case Assy.	1set	0243 0011 00 99
	(a) Motor Case	1	0230 0011 00 00
	(b) Hose Joint	1	0237 0113 00 00
	(c) Spring Roll Pin (6×12)	1	9250 1083 00 00
	Throttle Bushing Assy.	1set	0245 0104 00 99
	(d) Throttle Bushing	1	* ↑
	(e) "O"Ring (N15)	3	9010 4008 00 00
	Throttle Rod Bushing Assy.	1set	0117 0105 00 99
	(f) Throttle Rod Bushing	1	* ↑
	(g) "O"Ring (No.3)	1	9010 3003 00 00
	Throttle Rod Assy.	1set	2058 0106 00 99
	(h) Throttle Rod	1	* ↑
	(i) "O"Ring (N2)	1	9010 4001 00 00
	(j) Snap Ring (ETW - 2.8)	1	9040 5008 00 00
	(k) Throttle Knob	1	2024 0153 00 00
	(l) Spring Roll Pin (1.5×14)	1	9250 1005 00 00
	(m) Pin G (3×24)	1	8410 6024 00 00
	(n) Reverse Bushing	1	0128 0004 00 00
	(o) Reverse Valve	1	0128 0005 00 00
	(p) Spring (3×10)	1	8020 1004 00 00
	(q) Ball (1/8)	1	9150 3009 00 00
	(r) Snap Ring (IRTW - 12)	1	9040 3002 00 00
	Reverse Lever Assy.	1	0245 0007 00 99
	(s) Reverse Lever	1	* ↑
	(t) Spring Roll Pin (3×4.5)	1	9250 2004 00 00
	(u) Spring Roll Pin (3×14)	1	9250 1049 00 00
2	Silencer Assy.	1set	3048 0053 02 99
3	Motor Case Cover	1	0243 0001 00 00
4	Spring (20.5×12)	1	8020 1262 00 00
5	Spring (20.5×15)	1	8020 1261 00 00
6	Control Plate	1	0243 0226 00 00
7	Control Valve Assy.	1set	0245 0241 00 99
	(a) Control Valve	1	* ↑
	(b) "O"Ring (P22)	1	9010 1019 00 00
8	Control Bushing Assy.	1set	0243 0236 00 99
	(a) Control Bushing	1	* ↑
	(b) "O"Ring (N10)	1	9010 4004 00 00
9	Ball (M3.5)	3	9150 1004 00 00
10	Spring (5.8×14)	1	8020 1268 00 00
11	Control Shaft Assy.	1set	0243 0224 00 99
	(a) Control Shaft	1	* ↑
	(b) "O"Ring (N3)	1	9010 4025 00 00
12	S - Packing (A)	1	0230 0003 00 01
13	Hex. Socket Bolt (M5×18)	3	8070 3052 00 00
14	Spring Washer (M5)	3	9200 3005 00 00
15	Upper Plate Assy.	1set	0243 0303 00 99
	(a) Upper Plate	1	0243 0303 00 00
	(b) Ball Bearing (# 6000)	1	9100 1015 00 00
	(c) Spring Roll Pin (2×5)	2	9250 1010 00 00
16	Cylinder	1	0237 0304 00 00
17	Rotor	1	0243 0305 00 00
18	Vane	6	0213 0306 00 00
19	Lower Plate Assy.	1set	0228 0307 00 99
	(a) Lower Plate	1	0228 0307 00 00
	(b) Ball Bearing (# 6003)	1	9100 1018 00 00
	(c) Spring Roll Pin (2×5)	1	9250 1010 00 00

No.	Name of Parts	Per Set	Parts No.
20	Liner Case	1	0237 0422 00 00
21	"O"Ring (N45)	2	9010 4043 00 00
22	Liner Cap	1	0213 0423 00 00
23	Liner Upper Plate	1	0243 0424 00 00
24	"O"Ring (N39)	1	9010 4031 00 00
25	Sensor Assy.	1set	0245 0794 00 99
	(a) Sensor	1	* ↑
	(b) "O"Ring (P3)	1	9010 1001 00 00
26	Liner Assy.	1set	0243 0425 00 99
	(a) Liner	1	* ↑
	(b) Pin (3×7)	4	8052 1019 00 00
27	Relief Valve	1	0237 0245 00 00
28	Spring Guide (B) Assy.	1set	0243 0510 00 99
	(a) Spring Guide (B)	1	* ↑
	(b)"O"Ring (N3)	1	9010 4025 00 00
29	Check Valve Assy.	1set	0243 0251 00 99
	(a) Check Valve	1	* ↑
	(b)"O"Ring (N3)	1	9010 4025 00 00
	(c)"O"Ring (N2)	1	9010 4001 00 00
30	Spring Guide	1	0243 0510 00 00
31	Spring (4×20)	1	8020 1263 00 00
32	Ball (M4)	1	9150 1005 00 00
33	Main Shaft (1/2sq)	1	0243 0614 00 12
51	Plunger Assy.	1set	0237 0149 00 99
34	Blade	2	0241 0719 00 00
35	Spring (4×32)	2	8020 1251 00 00
36	Liner Lower Plate (A) Assy.	1set	0243 0426 00 98
	(a) Liner Lower Plate	1	0243 0426 00 00
	(b) Helisert (M4)	2	9050 2002 00 00
	(c) Screw (M4×14)	2	9480 2022 00 00
37	Oil Plug (M4)	1	0048 0010 00 00
38	Washer (6.5×8.5×1.1)	1	8040 1073 00 00
39	"O"Ring (N4)	1	9010 4021 00 00
40	"O"Ring (2.55×17.8×22.9)	1	9010 6017 00 00
41	Backup Ring (18×22.4×0.8)	1	9090 1006 00 00
42	"O"Ring (N6)	2	9010 4026 00 00
43	Spacer	1	0243 0119 00 00
44	S - Packing (B)	1	0123 0003 01 02
45	ST-Packing(17.5×21.5×0.2)	1	8011 1062 00 00
46	ST-Packing(17.5×21.5×0.3)	1	8011 1063 00 00
47	ST-Packing(17.5×21.5×0.5)	1	8011 1064 00 00
48	Hammer Case Assy.	1set	0243 0401 00 99
	(a) Hammer Case	1	0243 0401 00 00
	(b) Ball Bearing (# 6803ZZ)	1	9100 5027 00 00
	(c) Socket Plug (PT1/8)	1	8210 2001 00 00
49	Hex.Socket Bolt (M5×18)	3	8070 3052 00 00
50	Spring Washer (M5)	3	9200 3005 00 00

Standard Accessories

Hexagon Wrench (H2L)	1	9610 1013 00 00
Hexagon Wrench (H5)	1	9610 1006 00 00

Optional Part

33	Main Shaft (1/2sq)	1	0243 0614 00 12
----	--------------------	---	-----------------

The part marked "*" can not be supplied individually. So please order it as a unit of assembly shown by arrow mark (↑).