

# PNEUMATIC CHAIN HOIST TMH-20/4

THE HIGHEST LIFTING SPEED ON THE HOIST MARKET

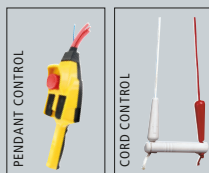
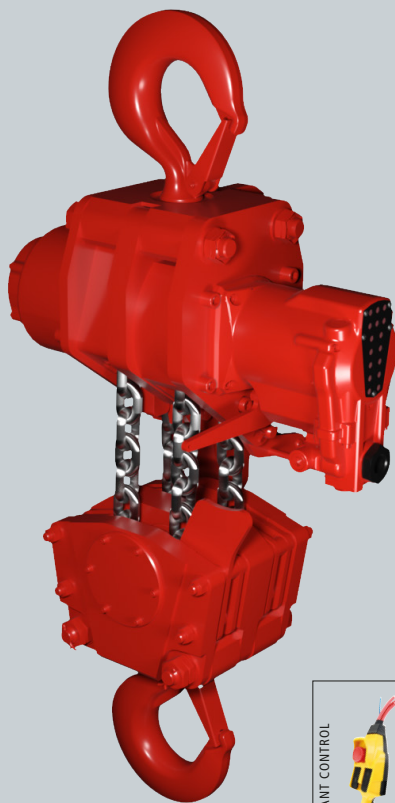

The new Red Rooster TMH series air chain hoists have the highest lifting speed. With M4 classification of mechanism this hoist is extremely reliable.

This hoist will guarantee the continuity of your process. The TMH hoists are designed with a supporting eye for easy installation.

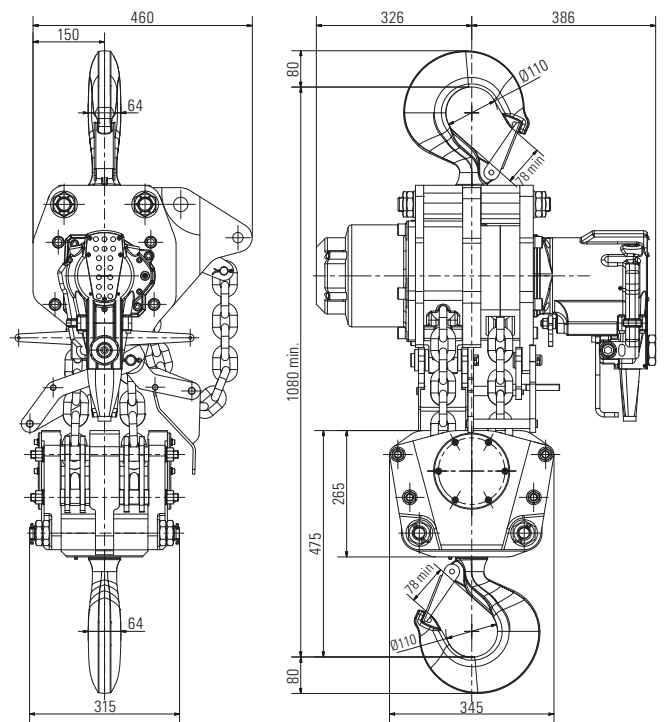

## STANDARD FEATURES

- Precise variable speed control (cord- and pendant control)
- Optimum control of the load, very precise positioning
- Mechanical end stop system, soft stop
- Load limiter built-in without loss of headroom
- Low noise level (83 dBA)
- Air pressure 0,4 - 0,63 MPa (4-6,3 bar)

WLL	Lifting speed with load	Lifting speed without load	Lowering speed with load	Air consumption lifting	Air consumption lowering	Air connection
20.000 kg	0,8 m/min	1,6 m/min	1,6 m/min	58 l/sec	71 l/sec	PT 1"
Minimum hose diam.	Working pressure	Weight with 3m hol	Additional meter hol	Chain falls		-
1"	0,4 - 0,63 MPa	397,3 kg	22,8 kg	4 (16 x 45 mm)		-